

Surname					Other Names				
Centre Number					Candidate Number				
Candidate Signature									

For Examiner's Use
--------------------

General Certificate of Secondary Education  
June 2008

**DESIGN AND TECHNOLOGY  
(GRAPHIC PRODUCTS)  
Written Paper  
Higher Tier**

**3543/H**

**H**



Thursday 19 June 2008 1.30 pm to 3.30 pm

**For this paper you must have:**

- a pen, a pencil, a ruler, an eraser, a pencil sharpener and coloured pencils.

You may also use marker pens and 45/60 degree set squares.

Time allowed: 2 hours

**Instructions**

- Use black ink or black ball-point pen.
- Fill in the boxes at the top of this page.
- Answer **all** questions.
- Answer the questions in the spaces provided.
- Show the working of your calculations.
- Detach the blue sheet from the back of this examination paper to use in between the sheets to prevent ink bleeding through to the next sheet.
- Do **not** hand in the blue sheet at the end of the examination.

**Information**

- The maximum mark for this paper is 125.
- The marks for questions are shown in brackets.
- All dimensions are given in millimetres unless otherwise stated.
- You are reminded of the need for good English and clear presentation in your answers.

**Advice**

- You are advised to answer the questions in this paper in the order in which they are written.

For Examiner's Use			
Question	Mark	Question	Mark
1		5	
2		6	
3		7	
4		8	
Total (Column 1) →			
Total (Column 2) →			
<b>TOTAL</b>			
Examiner's Initials			

This question is about the environment and evaluation and is worth 25 marks.

You are advised to spend about 20 minutes on this question.

1 Paper and board can be made from trees grown in *sustainable forests*.

(a) Explain, in detail, the term *sustainable forests*.

.....  
.....  
.....

(3 marks)

(b) A logo for an environmental organisation is shown below in **Figure 1**.



This logo has **four** design features. Two are identified below and two are not. Study each feature and evaluate its suitability for this environmental logo.

(i) Feature 1 represents the colour blue and is suitable because .....

.....  
.....

(2 marks)

(ii) Feature 2 represents a hand and is suitable because .....

.....  
.....

(2 marks)

(iii) Feature 3 represents .....

It is suitable because .....

.....

(3 marks)

(iv) Feature 4 represents .....

It is suitable because .....

.....

(3 marks)

(c) The logo in **Figure 1** is to be re-designed.

(i) In the space below, sketch the development of a new environmental logo based on the same four features used in **Figure 1**.



(6 marks)

(ii) Using your best ideas from part (c)(i) above, sketch your new logo in the space below.

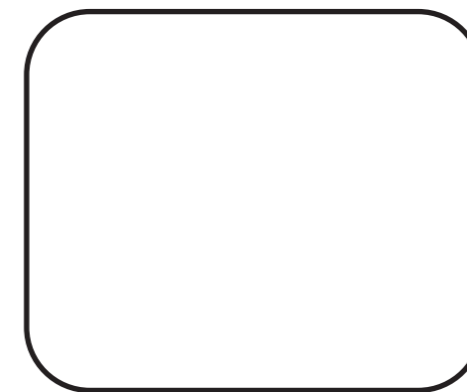

(3 marks)

(iii) Explain why your design is an improvement upon **Figure 1**.

.....  
.....  
.....

(3 marks)

Question 2 is about market researching and representing data and is worth 14 marks.

You are advised to spend about 15 minutes on this question.

2 A school wants to raise money by selling recordings of music performed by its students.

The Graphic Products department is to produce high quality packaging for the recordings.

To find out which recording format would be preferred, a questionnaire was sent to parents and students.

The results of the questionnaire are shown in the table opposite.

This data is to be shown as a pictograph.

(a) Give an advantage of using a pictograph to represent data.

.....

.....

.....

.....



(2 marks)

(b) Complete and colour the pictograph (**Figure 2**) using the data in the table below.

Each symbol in the pictograph represents 10%.

Marks will be awarded for:

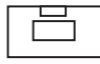
- (i) accuracy of data (4 marks)
- (ii) use of symbols (5 marks)
- (iii) quality of colouring. (3 marks)

Key	Format	Percentage
	Compact Disc	45%
	Video Cassette	20%
	DVD	25%
	Download	10%

**Figure 2**

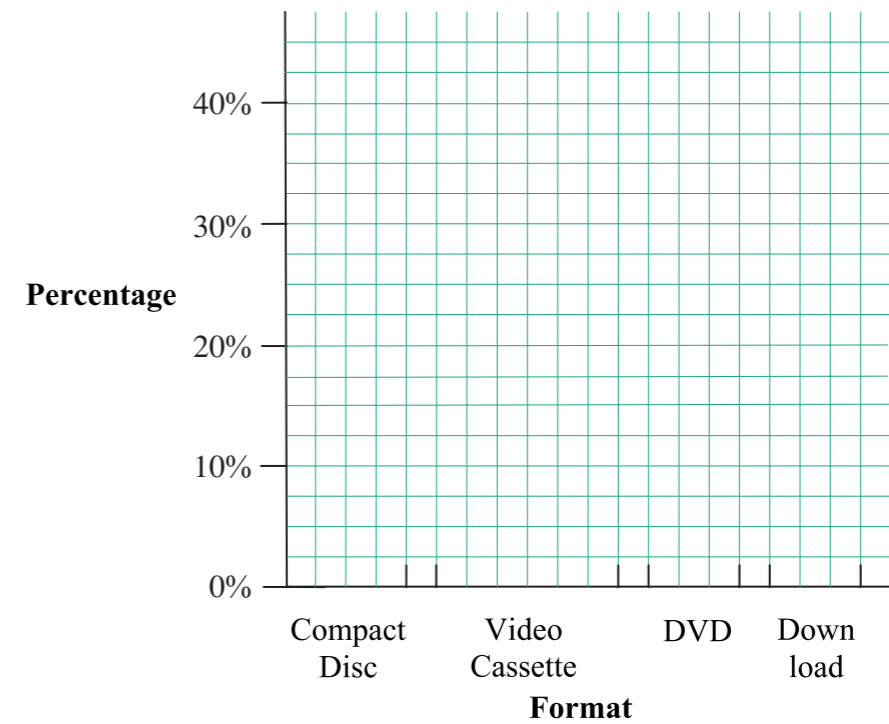

Question 3 is about typography and is worth 11 marks.

You are advised to spend about 10 minutes on this question.

3 The questionnaire showed that a Compact Disc (CD) was the preferred format for the school recording.

(a) Study the ideas web below showing different types of music.

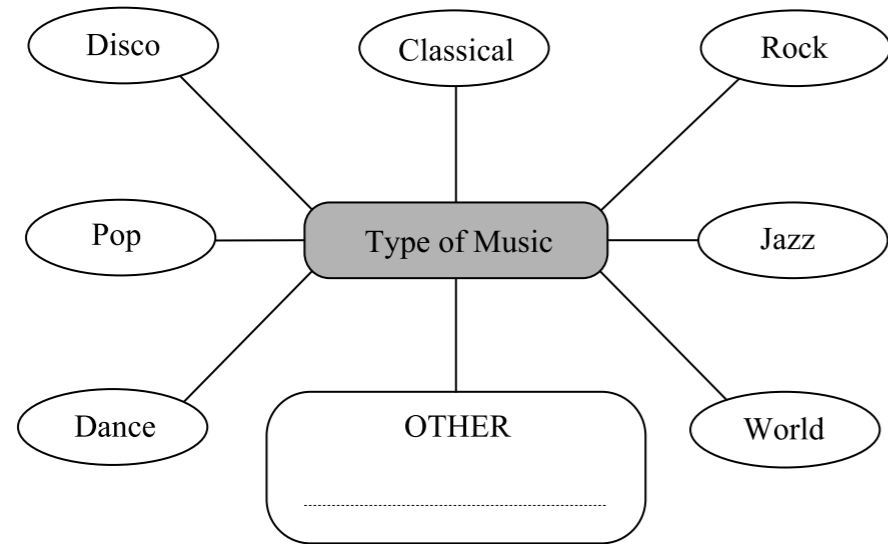

(i) Choose a type of music to be included on the school's CD.  
(If your favourite music is not listed, add it under OTHER.)

.....  
(1 mark)

(ii) Choose a suitable name for the school's CD. The name should be one or two words long and will be printed on the front of the CD cover.

.....  
(1 mark)

(b) In the spaces below, develop **three** different letter styles (fonts) for the name of your CD.

Letter style 1

Letter style 2

Letter style 3

(6 marks)

(c) My best letter style is number:

This letter style will be used in Question 4.

Explain why your best letter style is suitable for the CD.

.....  
.....  
.....  
.....

(3 marks)

This question is about developing a design and a presentation drawing and is worth 29 marks.

You are advised to spend about 30 minutes on this question.

4 You are to develop a design for an insert card for a CD jewel case, and a CD (Figure 3).

- (a) Sketch the development of a design for the insert card (Figure 4). (7 marks)
- (b) Produce a coloured presentation drawing of your final design (Figure 5). Include the name and letter style chosen in Question 3. (12 marks)
- (c) Modify your presentation drawing to fit on a CD (Figure 6). (7 marks)
- (d) Evaluate your CD design. (3 marks)

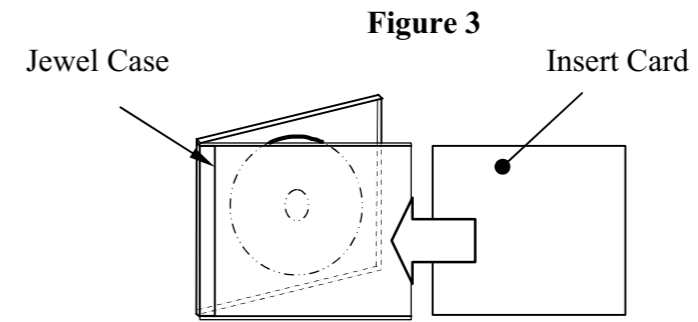

Figure 3

(a) First design

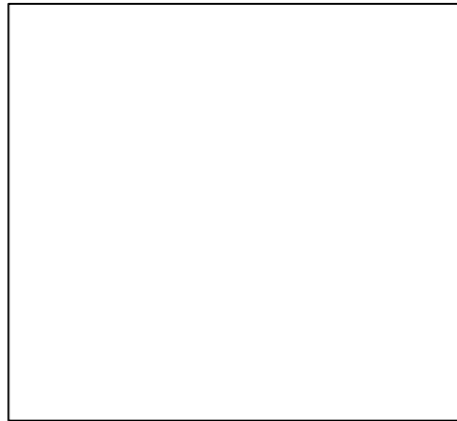

Figure 4

Improved design

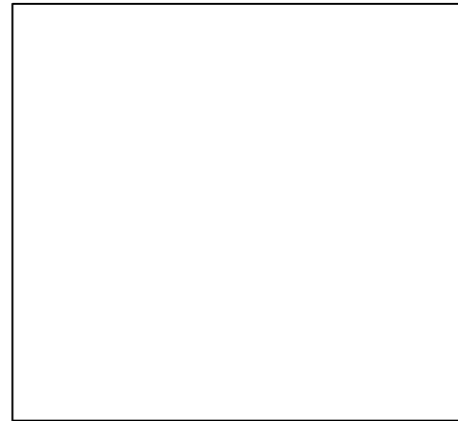

Figure 5

(b) Presentation drawing

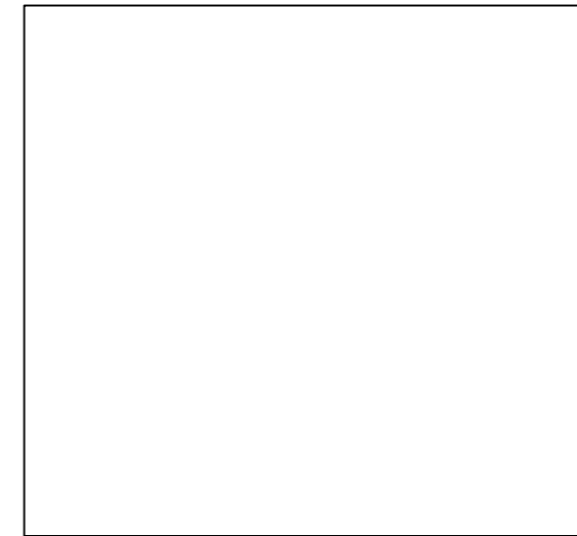
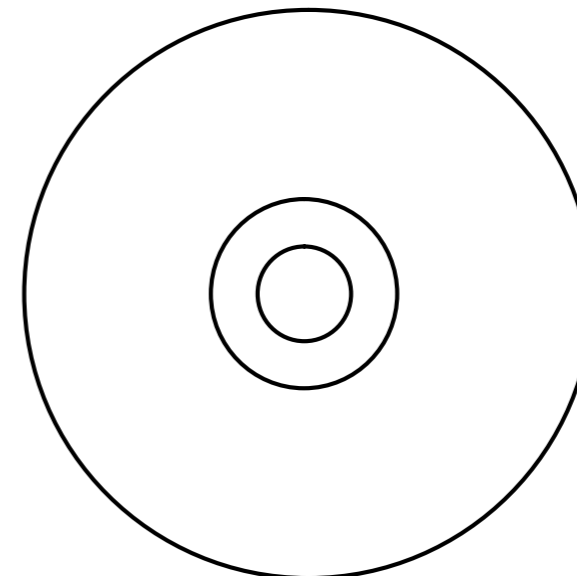

Figure 6

(c) Modified presentation drawing



(d) Evaluate your CD design

.....

.....

.....

.....

This question is about surface development (net) and is worth 11 marks.

You are advised to spend about 10 minutes on this question.

5 **Figure 7** shows a double CD sleeve. The sleeve can be cut from a single piece of thin board (card) measuring 490 mm by 170 mm.

Complete the *half full size* surface development (net) of the double CD sleeve on the grid below (**Figure 8**) using the given key. Estimate any sizes not given.

Include glue tabs 20 mm wide.

(11 marks)

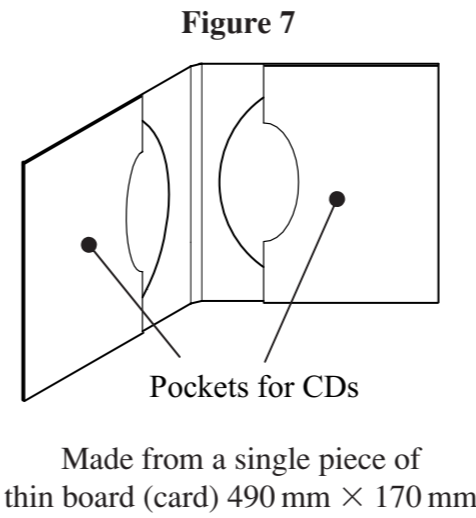

**Figure 8**

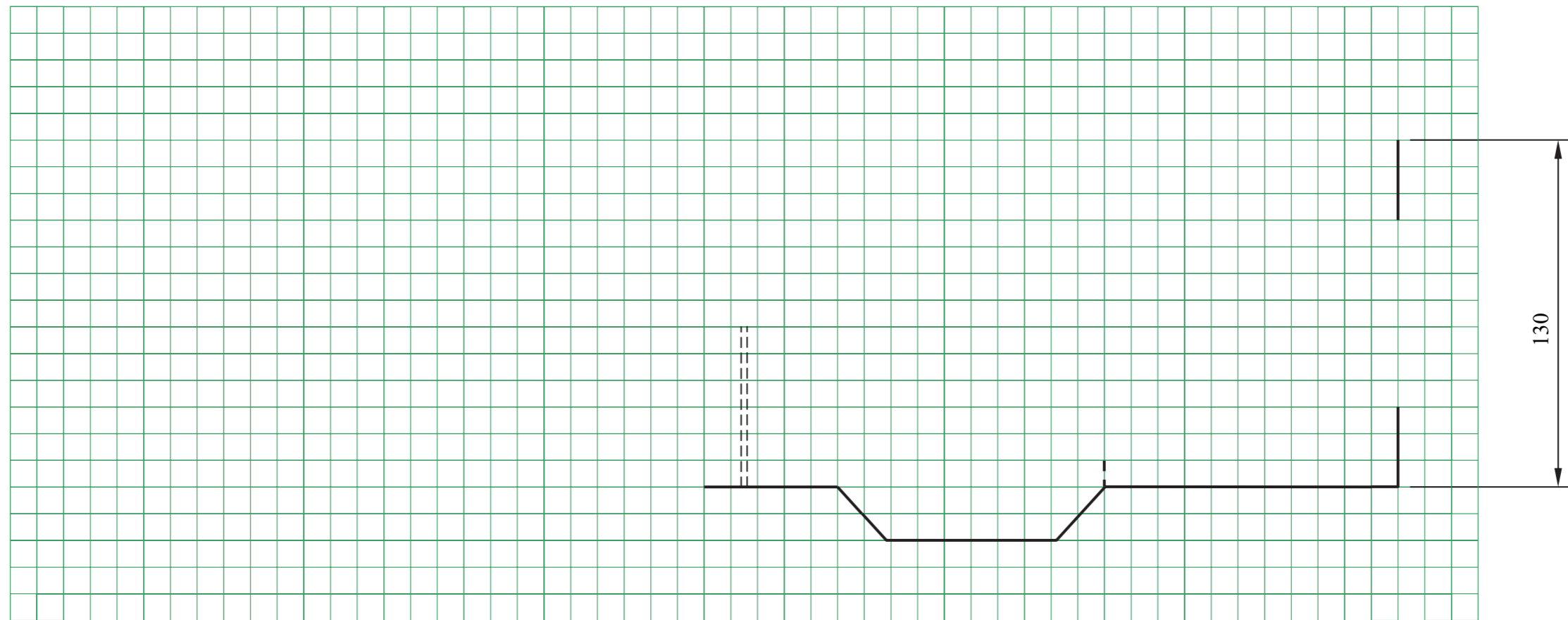

Key	
—————	Cut line
- - - - -	Fold line

Scale 1 : 2

This question is about creating an image and is worth 11 marks.

You are advised to spend about 10 minutes on this question.

6 The art work for a different CD cover can be designed in a school's graphics studio.

The final design, **Figure 11**, is made from elements taken from the other pictures (**Figure 9** and **Figure 10**).

You should explain how this is achieved **either** by using hand tools and equipment **or** by using Computer Aided Design (CAD) methods.

**Figure 9**



**Figure 10**



**Figure 11**



**USING HAND TOOLS AND EQUIPMENT**

- (a) Complete **Table 1** by describing the stages used to create **Figure 11** from the two photographs. (4 marks)
- (b) Name a tool **or** piece of equipment used at each stage. (4 marks)

**Table 1**

Stage Number	Description of stage	Name a tool or piece of equipment used at each stage
1	<i>Obtain photographs of the guitar, its case and the sea view.</i>	<i>A camera</i>

(c) In the space below sketch and name **one** of the tools or pieces of equipment you would use.

Name of tool **or** equipment ..... (3 marks)

OR

**USING COMPUTER AIDED DESIGN METHODS**

- (a) Complete **Table 2** by describing the stages used to create **Figure 11** from the two computer images. (4 marks)
- (b) Name a computer **or** toolbar icon used at each stage. (4 marks)

**Table 2**

Stage Number	Description of stage	Name a computer or toolbar icon used at each stage
1	<i>Download and save the two images from the Internet.</i>	<i>Save</i>

(c) In the space below sketch and name **one** of the computer or toolbar icons you would use.

Name of icon ..... (3 marks)

OR

This question is about materials and components and is worth 17 marks.

You are advised to spend about 15 minutes on this question.

7 (a) Some CDs contain information booklets.

In this booklet information is printed on both sides of two sheets of paper, folded and stapled together (Figure 12).

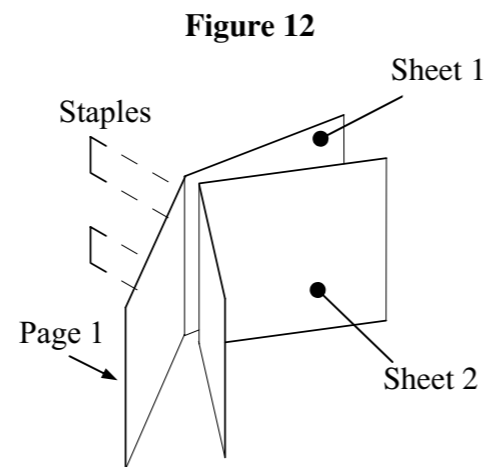
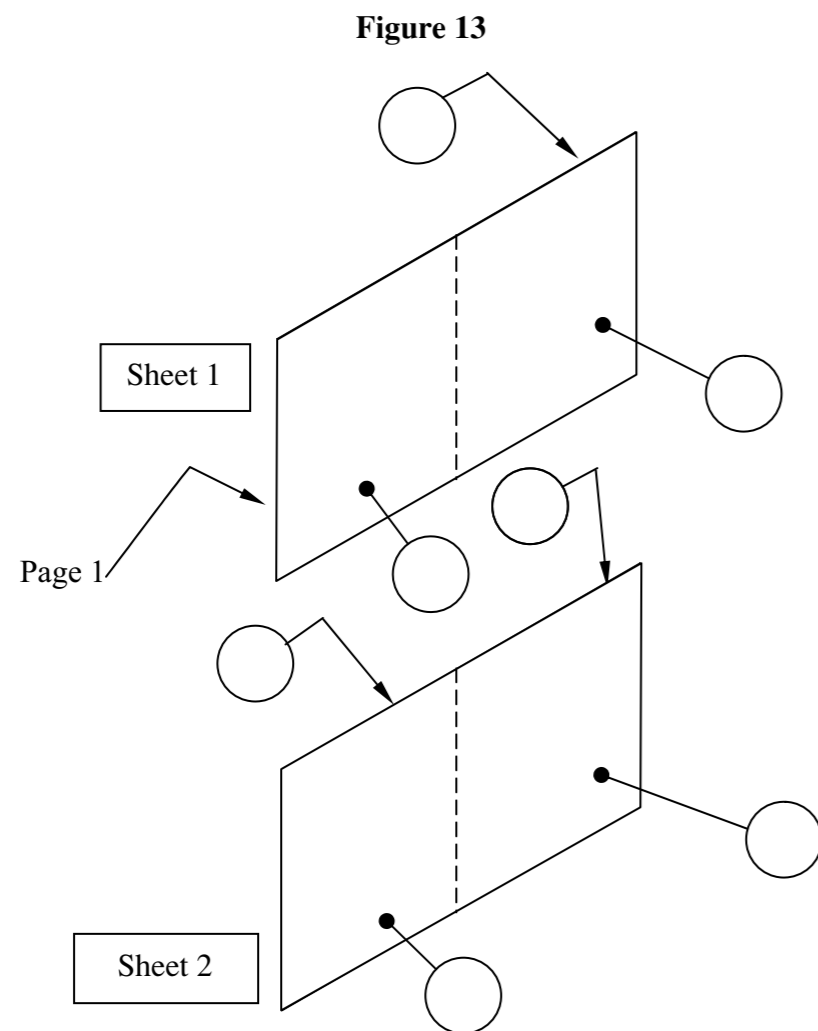

Figure 13 shows the two sheets of the booklet. Page 1 is labelled.

Enter the missing page numbers in the circles.

(5 marks)



(b) A *mock up* CD sleeve can be made in a school's graphics studio.

(i) What is a *mock up*?

.....  
.....  
.....  
.....  
(3 marks)

(ii) The CD sleeve is made from 200 gsm thin board.

Give the full meaning of 200 gsm.

.....  
.....  
.....  
.....  
(3 marks)

(iii) What would be the effect of using recycled board for the CD sleeve?

.....  
.....  
(2 marks)

(iv) When felt-tip pens are used on some kinds of paper the colour can 'bleed'. Explain the term 'bleed'.

.....  
.....  
(2 marks)

(v) Explain a safety precaution you should observe when using a spray adhesive.

.....  
.....  
(2 marks)

This question is about production techniques and is worth 7 marks.

You are advised to spend about 10 minutes on this question.

8 Promotional CDs are often held inside a thin board holder (**Figure 14**).

**Figure 15** shows the outline of the holder and its CD.

(a) Use sketches and notes on **Figure 15** to show how the holder could be modified to hold the CD securely *without* having to use additional materials or adhesives.

**Figure 14**

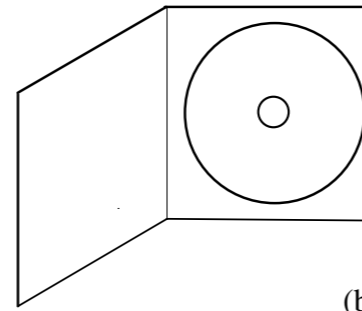

(5 marks)

(b) The thin board is folded along the 'fold line'. It can be folded by either *creasing* or *scoring* the line first.

Explain why *creasing* is preferable to *scoring*.

.....

.....

.....

.....

.....

.....

(2 marks)

**Figure 15**

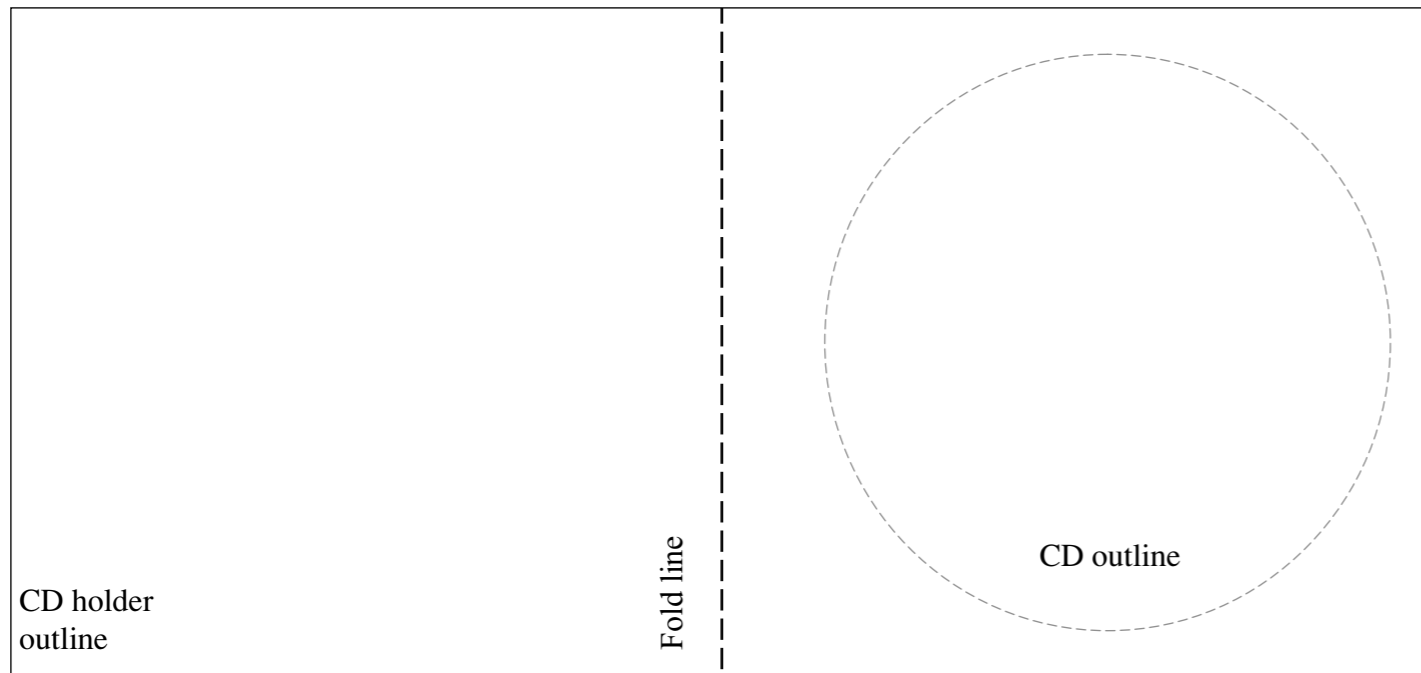

**END OF QUESTIONS**

ACKNOWLEDGEMENT OF COPYRIGHT-HOLDERS AND PUBLISHERS

Permission to reproduce all copyright material has been applied for. In some cases efforts to contact copyright-holders have been unsuccessful and AQA will be happy to rectify any omissions of acknowledgements in future papers if notified.

Copyright © 2008 AQA and its licensors. All rights reserved.